

CLASS 10000 HD SERIES 48 EC *Moore* FANS

EXTENDED CHORD, RH ROTATION

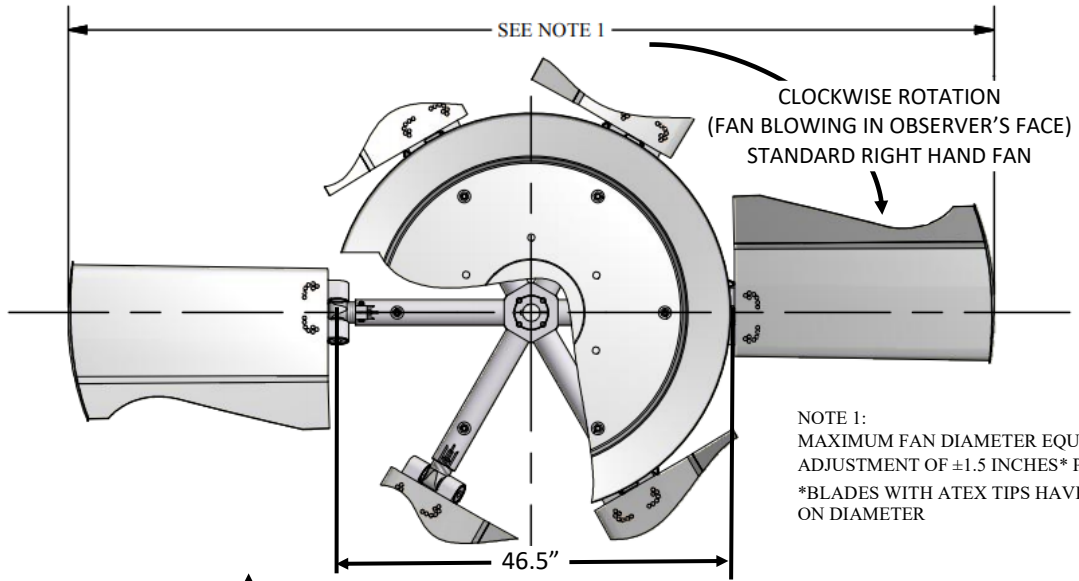

NOTE 1:
 MAXIMUM FAN DIAMETER EQUALS NOMINAL FAN DIAMETER.
 ADJUSTMENT OF ±1.5 INCHES* POSSIBLE AT INSTALLATION
 *BLADES WITH ATEX TIPS HAVE ADJUSTMENT OF -1.0" & +2.0" ON DIAMETER

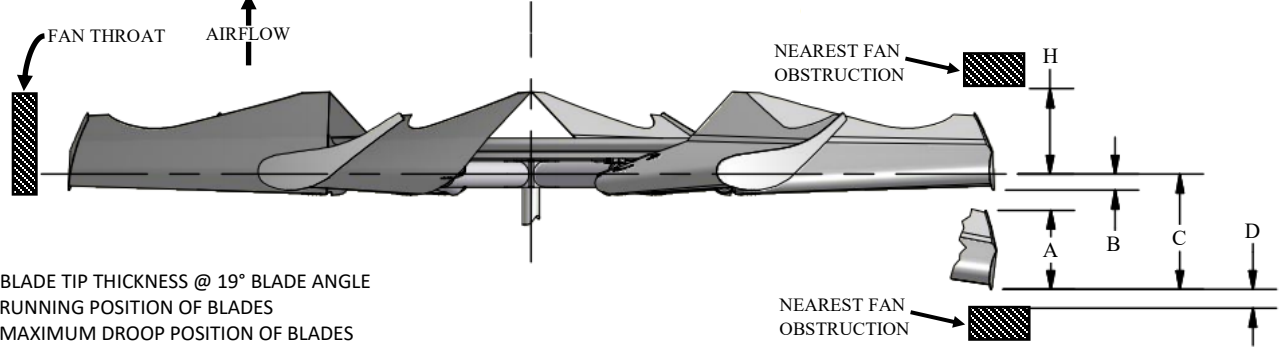

- A = BLADE TIP THICKNESS @ 19° BLADE ANGLE
- B = RUNNING POSITION OF BLADES
- C = MAXIMUM DROOP POSITION OF BLADES
- D = MINIMUM OBSTACLE CLEARANCE AT INLET
- F = CENTERLINE OF FAN TO BASE OF BUSHING
- G = BUSHING OVERALL HEIGHT
- H = MINIMUM OBSTACLE CLEARANCE AT OUTLET
- I = NOMINAL MECHANICAL HUB DIAMETER
- L = MAXIMUM BUSHING TORQUE FT. LBS.
- # = WITH S.A.E. STANDARD SQUARE KEYWAY
- * = WITH SHALLOW KEYWAY IN BUSHING
- ◊ = MAX METRIC BORE WITH STANDARD KEYWAY

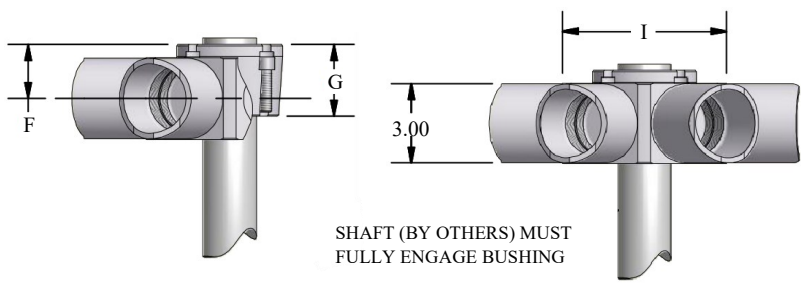

BUSHING AND/OR AIR SEAL CAN BE INSTALLED ON INLET OR OUTLET SIDE OF FAN

WITH FAN OPERATING AT 12000 FT/MINUTE BLADE TIP SPEED

DIA	PERCENT BLADE LOADING					
	100%		75%		H	
	A	B	C	D		
8'	7.5"	5.1"	4.8"	5.8"	2.0"	14.0"
9'	7.5"	5.7"	5.3"	6.9"	2.0"	14.0"
10'	7.5"	6.5"	5.9"	8.1"	2.0"	14.0"
11'	7.5"	7.5"	6.7"	9.6"	2.0"	14.0"
12'	7.5"	8.6"	7.5"	11.4"	2.0"	14.0"
13'	7.5"	9.9"	8.5"	13.3"	2.0"	14.0"
14'	7.5"	11.3"	9.5"	15.4"	2.0"	14.0"
15'	7.5"	12.8"	10.7"	17.8"	2.0"	14.0"
16'	7.5"	14.5"	12.0"	20.4"	2.0"	14.0"

MAX BLADES	BUSHING TYPE	MAX # BORE	MAX * BORE	MAX ◊ BORE	I	F	G	L
6	U	2.750"	2.938"	75	7"	2.0"	2.7"	4000
8	U	2.750"	2.938"	75	9"	2.0"	2.7"	4000
12	U	2.750"	2.938"	75	12"	2.0"	2.7"	4000
8	W	3.750"	4.000"	100	9"	2.2"	2.8"	7300
12	W	3.750"	4.000"	100	12"	2.2"	2.8"	7300
10	Z	5.000"	5.500"	140	12"	2.2"	4.0"	18000